

Compression Load Cell

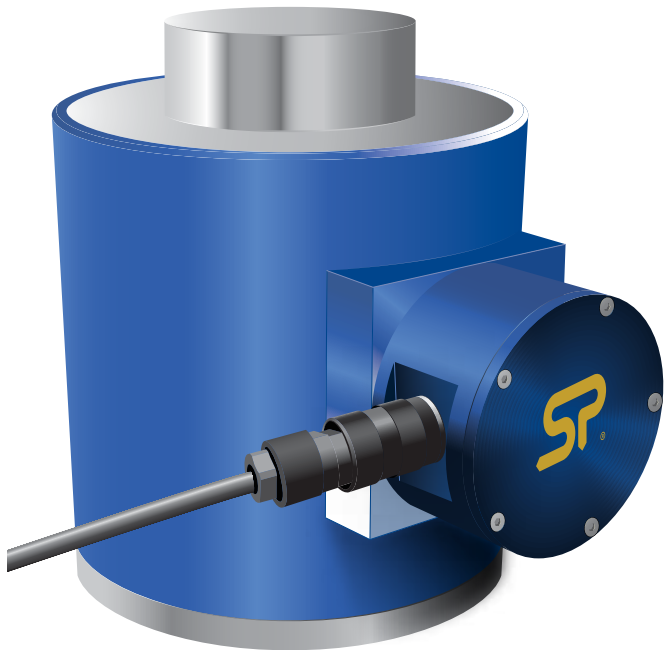

Features and benefits:

- Compact size
- Environmentally sealed to IP67/NEMA6
- Optional analogue outputs
- Stainless steel element
- High accuracy
- Lightweight
- Unrivalled resolution
- Custom versions available
- Design validated by F.E.A.



Requires connection to Straightpoint's Handheld plus (HHP), Desktop Controller data logging software (DCP10M) or External Amplifier range (SA-3420) that can be configured to provide outputs such as 4-20mA, 0-10v, 0-5v for PLC or data logger integration.

Manufactured in ranges from 5t to 500t - other capacities available on application.

Straightpoint compression load cells are manufactured to the same stringent standards as all Straightpoint products. The bodies are machined from high grade stainless steel, offering excellent strength and anti-corrosion properties. Compression load cells can be supplied with optional loadcaps to protect objects being tested.

The compact lightweight design provides ease of use and superior portability, allowing Straightpoint compression load cells to be used in a broad range of industries including mining, energy, defence, heavy rigging, shipping, and general transportation sectors.

Utilising the same advanced microprocessor based electronics as all Straightpoint products, Straightpoint's compression load cells benefit from high sampling rates, extreme resistance to industrial level noise and unprecedented stability. This high stability gives this product over 5,000 divisions and the highest standard resolution of any high capacity compression load cell on the market today.

Like all Straightpoint products, Straightpoint compression load cells offer robust construction, advanced electronics, industry leading resolution and accuracy all at a cost-effective, affordable price.



making the lifting industry a safer place

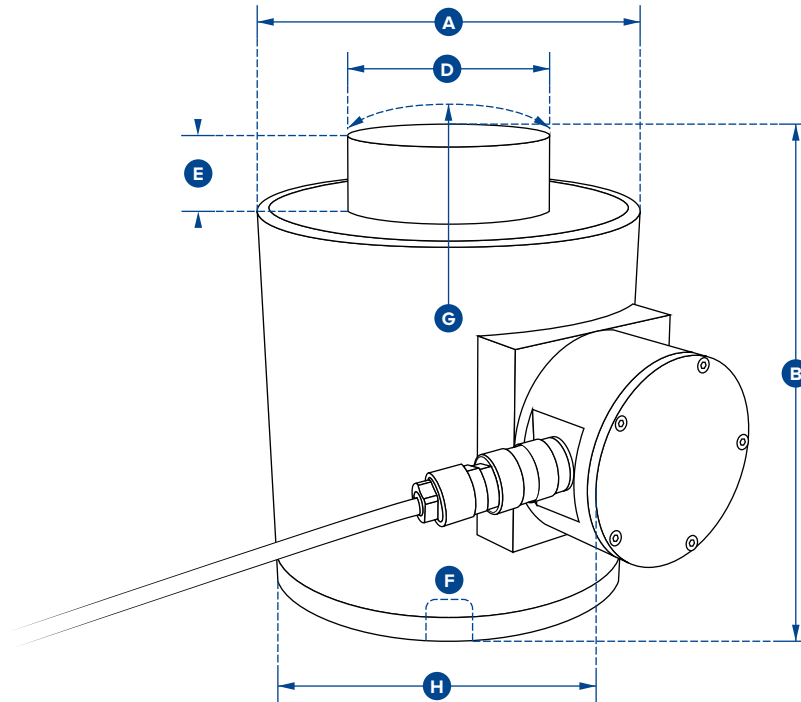

Part Number	NI5TC	NI10TC	NI25TC	NI50TC	NI100TC	NI150TC	NI300TC	NI500TC
Capacity	5te	10te	25te	50te	100te	150te	300te	500te
	11000lb	22000lb	55000lb	110000lb	220000lb	330000lb	660000lb	1100000lb
Resolution	0.001te	0.002te	0.005te	0.01te	0.05te	0.05te	0.1te	0.2te
	2lb	5lb	10lb	20lb	100lb	100lb	200lb	500lb
Units	tonne							
	lb							
Weight	3.2kg	3.2kg	3.2kg	6.2kg	15.5kg	15.5kg	65kg	65kg
	7lb	7lb	7lb	13.64lb	34lb	34lb	143lb	143lb
Safety Factor	3:1							
Operating Temp	-10°C to +50°C / 14°F to 122°F							
Accuracy	±0.3% of applied load							
Protection	IP67 / NEMA 6							
Dimension ØA	76	76	76	102	152	152	185	185
	2.99"	2.99"	2.99"	4.02"	5.98"	5.98"	7.28"	7.28"
Dimension B	83	83	83	127	184	184	300	300
	3.27"	3.27"	3.27"	5.00"	7.24"	7.24"	11.81"	11.81"
Dimension ØD	32	32	32	59	80	80	155	155
	1.26"	1.26"	1.26"	2.32"	3.15"	3.15"	6.10"	6.10"
Dimension E	10	10	10	13	26	26	27.5	27.5
	0.39"	0.39"	0.39"	0.51"	1.02"	1.02"	1.08"	1.08"
Dimension F	M12 x 1.75	M12 x 1.75	M12 x 1.75	M20 x 2.5	M20 x 2.5	M20 x 2.5	M20 x 2.5	M20 x 2.5
	M12 x 1.75	M12 x 1.75	M12 x 1.75	M20 x 2.5	M20 x 2.5	M20 x 2.5	M20 x 2.5	M20 x 2.5
Dimension G	152	152	152	152	432	432	432	432
	5.98"	5.98"	5.98"	5.98"	17.01"	17.01"	17.01"	17.01"
Dimension H	96	96	96	154	204	204	237	237
	3.78"	3.78"	3.78"	6.06"	8.03"	8.03"	9.33"	9.33"

Handheld plus



Features and benefits:

- Overload counter
- User settable 90db audible overload alarm
- Multiple display units – tonnes, lbs, kg and kN
- 100Hz Peak hold
- Pre-set tare
- Wireless range 700m/2300ft

The Handheld plus is a rugged and versatile digital handheld display with a broad range of features and suitable for all Straightpoint load cell products.

At the heart of the ergonomically designed Handheld plus is a powerful PCB providing industry leading features such as user selectable units of measure (tonnes, lbs, kg and kN), programmable audible overload alarm, peak hold, pre-set tare and a user resettable overload counter.

This crucial overload alarm counter is a requirement for many safety and quality control departments, as it keeps track of overload events, allowing the load cell in question to be removed from service immediately, following the calibration voiding overload event. The load cell in question can then be sent out for proper testing and, if necessary, recalibration before re-entering service.

The HHP is suitable for connection via cable to any Straightpoint cabled load cell product and easily adapted to any other manufacturers' load cell product with a mv/v output.

In addition to the standard HHP the SW-HHP is suitable for connection to any Straightpoint wireless load cell, has a range of up to 700m/2300ft and is supplied as standard with the Radiolink plus load cell.

Part Number	SW-HHP	HHP
Battery Type	2 x AA	1 x PP3 9v alkaline
Battery Life	60hrs continuous	80hrs continuous
Display Type	6 digit 25mm LCD / 6 digit 1" LCD	
Operating Temp	-10°C to +50°C / 14°F to 122°F	
Display Rate	3Hz	
Protection	IP65 / NEMA 4X	
Excitation	N/A	5v
Max Sensitivity	N/A	3mv/v
Max Resolution	1:999999 (normal mode)	
Connectivity	Wireless 2.4GHz	6-way female binder 423 socket



making the lifting industry a safer place

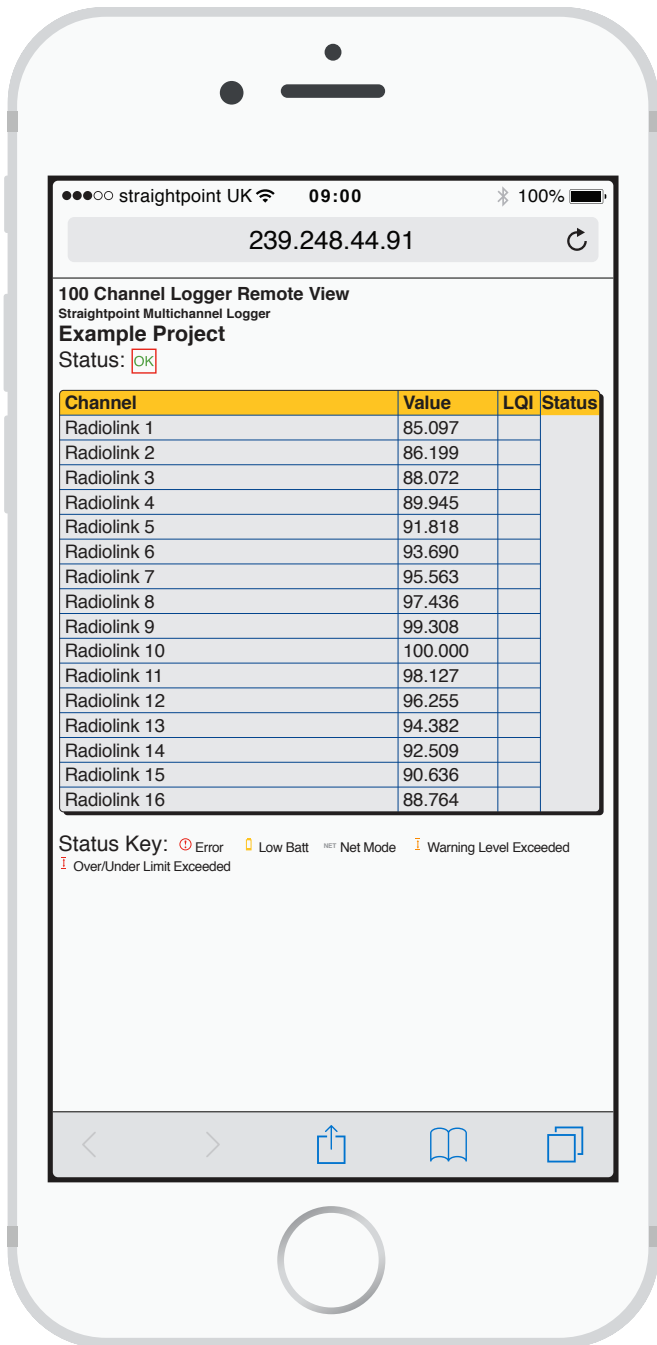

Date	Time	Elapsed mS	Radiolink 1	Radiolink 2	Radiolink 3	Radiolink 4	Total Load
10/03/2015	10:41:38	1000	0.01	0	0	0.02	0.03
10/03/2015	10:41:39	2000	0.23	0.16	0.03	0.59	0.73
10/03/2015	10:41:40	3000	3.04	0.16	1.6	2.23	14.17
10/03/2015	10:41:41	4000	5.3	0.94	1.6	7.62	32.45
10/03/2015	10:41:42	5000	5.5	1.9	1.6	8.1	36.72
10/03/2015	10:41:43	6000	8.39	4.09	4.42	9.87	46.37
10/03/2015	10:41:44	7000	9.99	5.11	6.26	12.13	62.56
10/03/2015	10:41:45	8000	11.8	6.43	7.43	19.14	72.8
10/03/2015	10:41:46	9000	11.79	6.2	6.18	17.06	73.85
10/03/2015	10:41:47	10000	8.01	2.43	2.3	12	52.72
10/03/2015	10:41:48	11000	4.94	0.02	0.01	6.09	32.69
10/03/2015	10:41:49	12000	0.06	0.01	0	4.08	15.19
10/03/2015	10:41:50	13000	0	0	0	0	-3.53

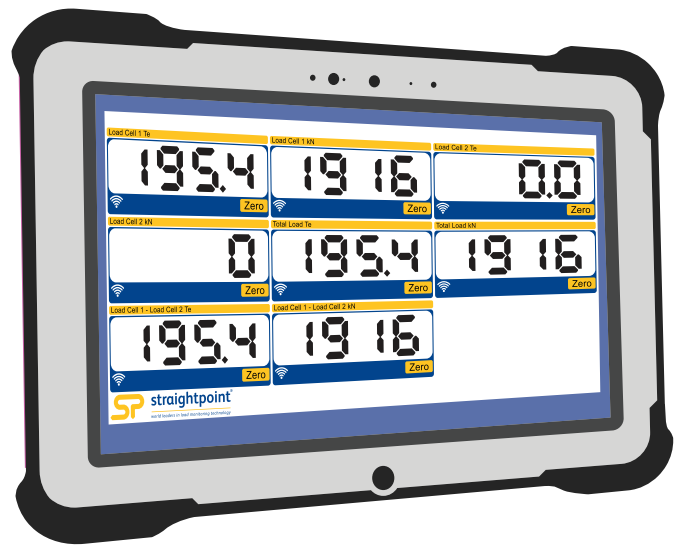
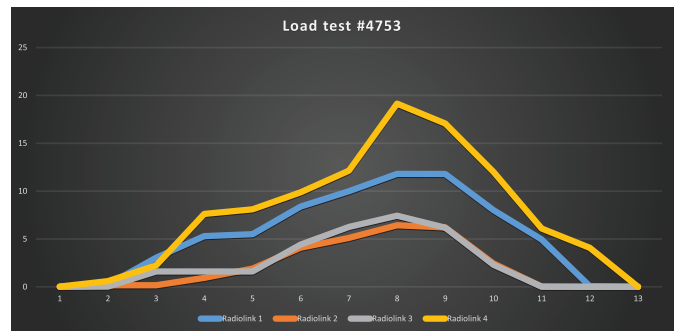



Straightpoint's Multiple Wireless Load Cell Controller (SW-MWLC) software package is a versatile, user friendly, wireless load cell control, display and data logging tool designed for use on the Windows PC platforms, Vista, Win 7, 8 & 10.

SW-MWLC allows simultaneous, wireless communication between Straightpoint wireless load cells and a Windows PC. A resizable window displays a table of up to 100 wireless load cell channels of live data. Channels can be setup with user defined mathematical functions that can be used to calculate a multitude of results.

For example, a display can show the value from a single load cell or the sum of multiple load cells. Visual display and audio alarms can indicate under and over range as well as loss in communications, low battery and error reports. SW-MWLC can log on demand, at pre-set intervals, on entering and leaving a pre-set overload and during an overload. Data is logged to a CSV file which can be opened for analysis by software programs such as Microsoft Excel. JSON format data is also available on demand via the built in web server.

For more complex applications, graphical pages can be built showing the data in a variety of formats including digital display or bar graphs. Up to eight pages can be defined and the pages easily navigated between a variety of image formats that can be imported, including JPG, GIF, PDF and DXF.

Custom applications including branding and colour scheme are available. Please contact Straightpoint's sales department for pricing.

SW-MWLC software is supplied with a SW-USBBSE extended range USB transceiver.

Features and benefits:

- Displays and logs data up to 100 Straightpoint wireless load cells simultaneously
- Mapping/graphical capabilities
- Webserver offers remote viewing on iPads/tablets/smart phones and also supplies JSON data on demand
- Logging at timed intervals, manual or on overload/underload
- Visual and audible alarms indicates overload, low battery and communications error
- Zoom in to channel to see data trends and history
- Export and log data in CSV format

Part Number	SW-MWLC
IP rating (SW-USBBSE)	IP54 NEMA 3
Operating Temp	-10°C to +50°C 14°F to 122°F
Licence	Licence free
Frequency	2.4 GHz
Range	700 metres 2300 feet
Load Cell Inputs	Up to 100
PC Requirements	Intel i3 processor with 2GB RAM
Operating System	Windows XP, Vista, Windows 7, 8 or 10